

autovictor

 *Keep on moving to the future.*

MANUALE TECNICO
ORMIG 302 TTV

DIMENSIONI GENERALI - OVERALL DIMENSIONS - DIMENSIONS D'ENCOMBREMENT

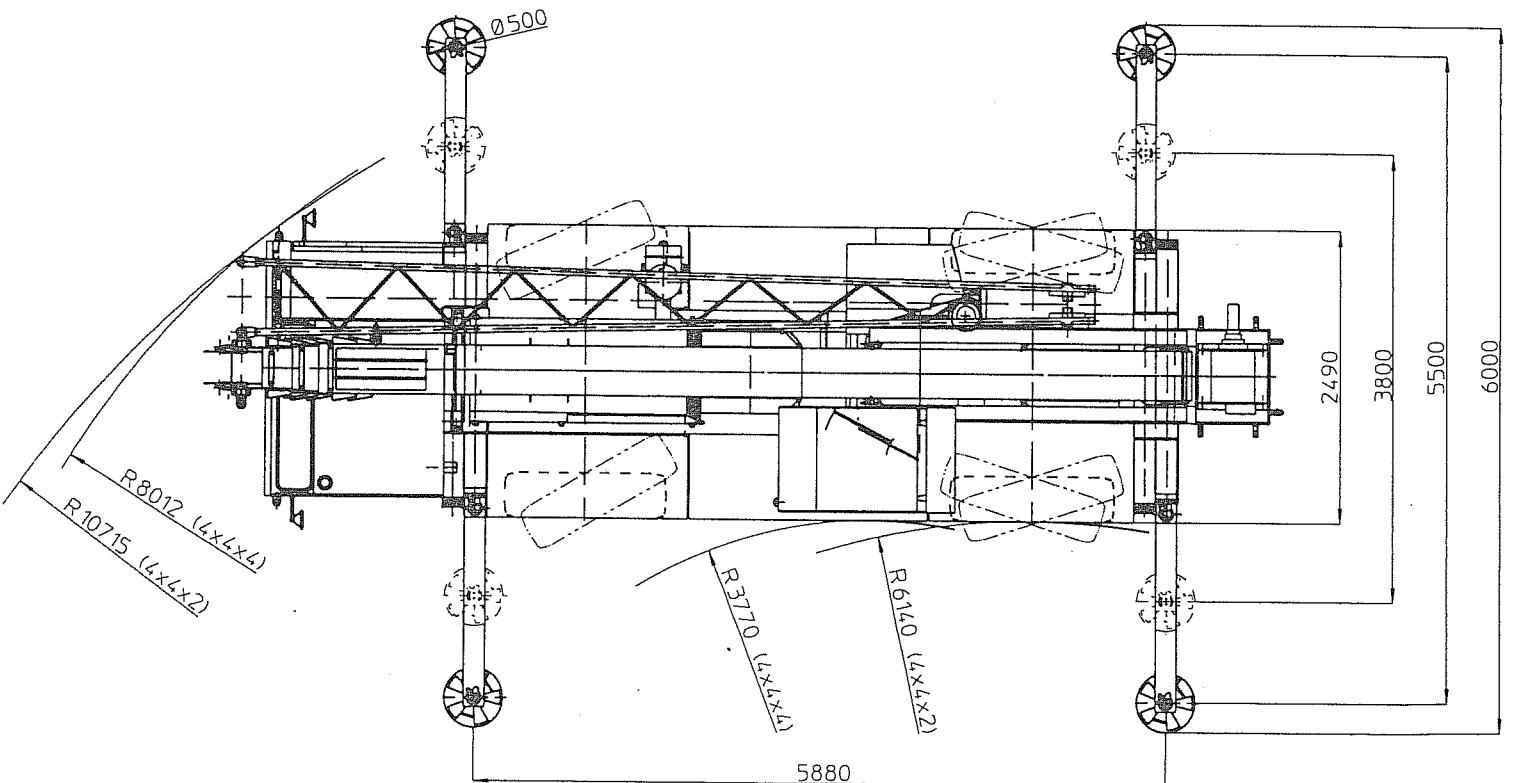
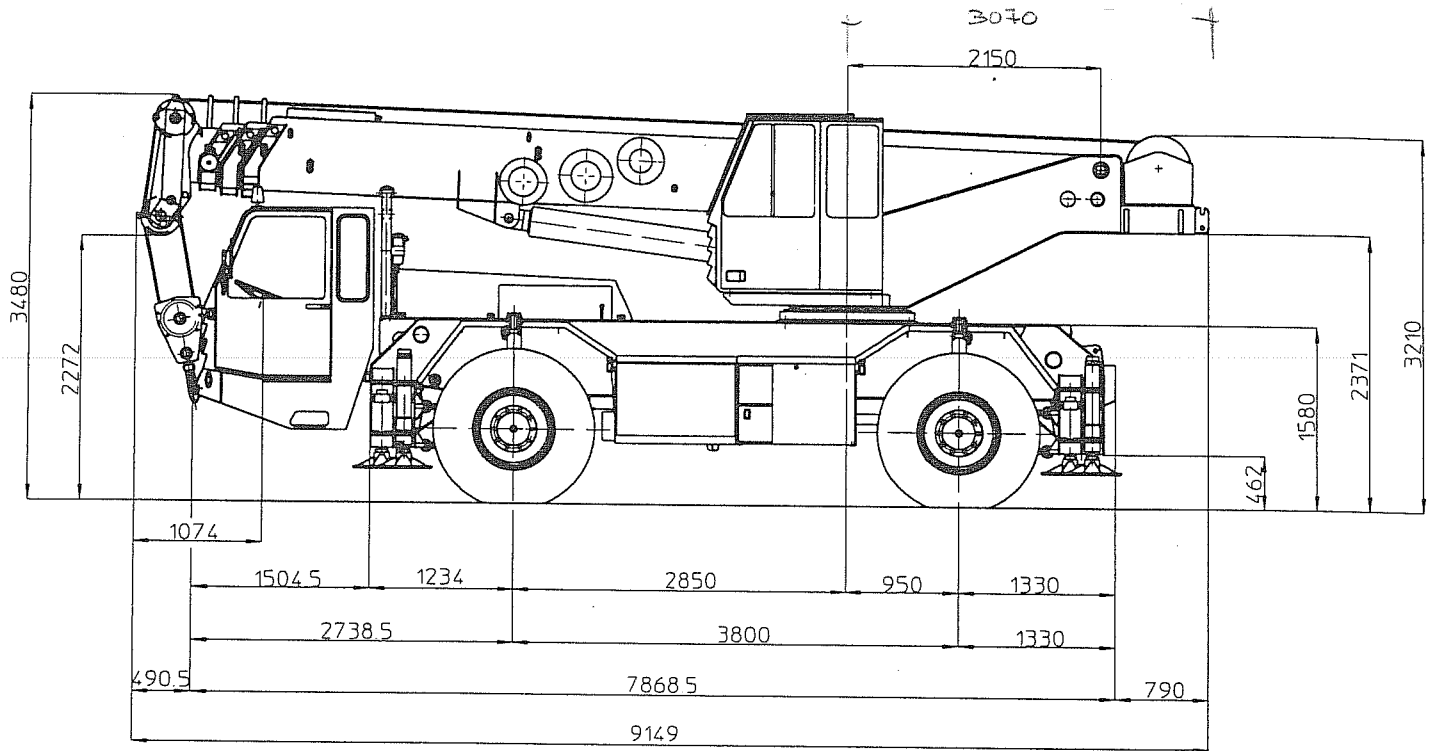

302 ttv

DIAGRAMMA CAMPO DI LAVORO

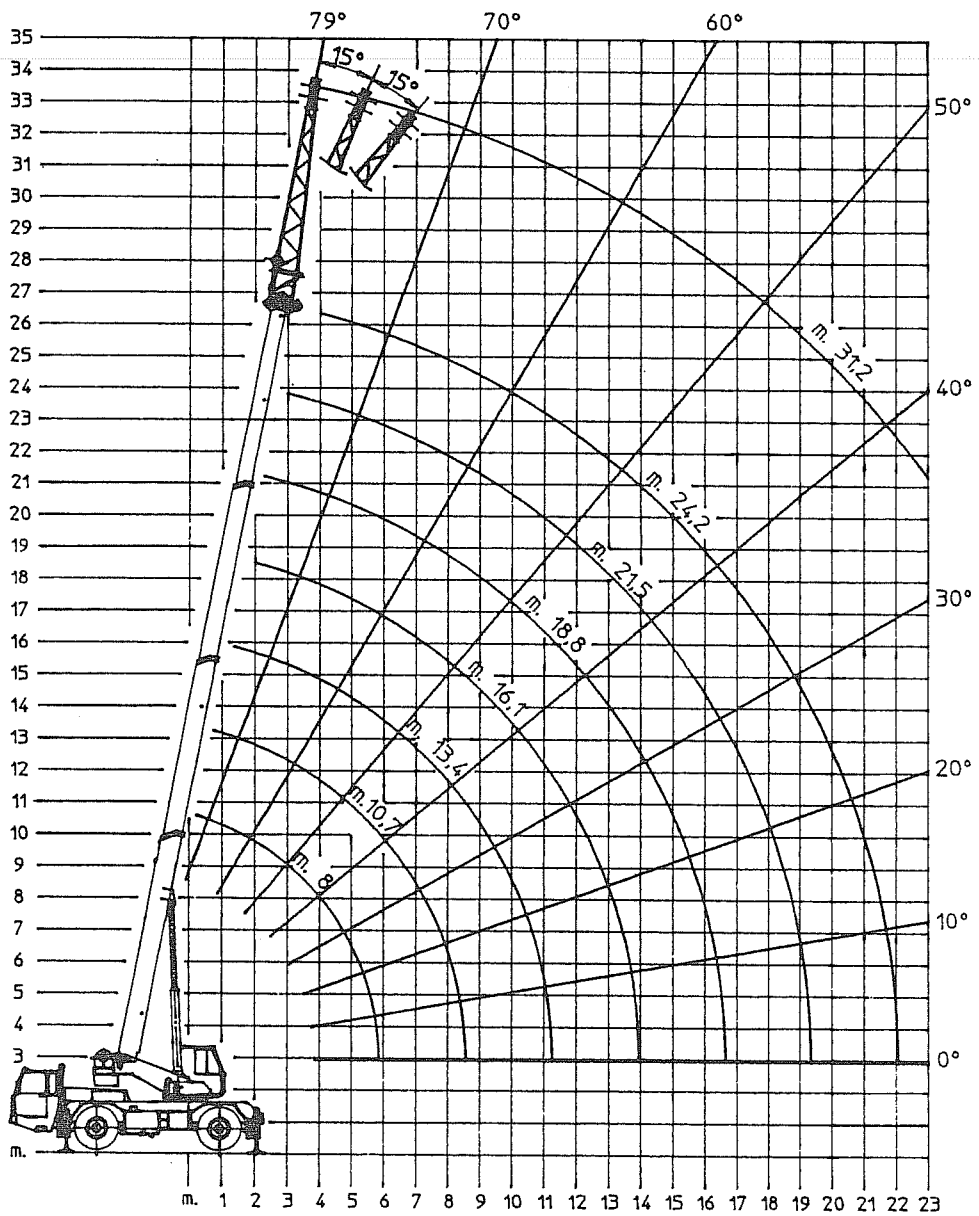

302 ttv

PORTATE BRACCETTO TRALICCIATO

m 7 FISSO

PORTATA BRACCETTO TRALICCIATO m 7 (CON BRACCIO m 24,2) MACCHINA STABILIZZATA (m 5,88 x 5,5)				
RAGGIO DI LAVORO DAL CR.	ANGOLO BRACCIO Δ	ZAVORRA STANDARD N°2 FUNI	ZAVORRA 2800 Kg N°2 FUNI	RAGGIO DI LAVORO DAL CR.
6	75.1	3.2	3.2	6
7	73.2	3.1	3.1	7
8	71.3	3.0	3.0	8
9	69.3	2.9	2.9	9
10	67.3	<u>2.8</u>	2.8	10
11	65.3	2.6	2.7	11
12	63.3	2.3	2.6	12
13	61.2	1.9	2.5	13
14	59.1	1.7	2.3	14
15	57	1.5	<u>2.2</u>	15
16	54.7	1.3	2.0	16
17	52.4	1.1	1.8	17
18	50	0.9	1.6	18
19	47.6	0.8	1.4	19
20	45	0.6	1.2	20
21	42.4	0.5	1.1	21
22	39.6	0.4	0.9	22
23	36.5	---	0.8	23
24	33.3	---	0.7	24
25	29.8	---	0.6	25
26	---	---	---	26

N.B. Le portate al di sopra della linea in grassetto sono limitate da fattori diversi dal ribaltamento

autovictor

 *Keep on moving to the future.*

MANUALE TECNICO ORMIG 302 TTV

AUTOVICTOR s.r.l.

Via Galvani 11/13

28060 San Pietro Mosezzo - Novara

Tel. +39 0321 35000

info@autovictor.it

www.autovictor.it